



Equipment Manual

Each product and program carries a respective written warranty, the only warranty on which the customer can rely. Monarch reserves the right to make changes in the product and the programs and their availability at any time and without notice. Although Monarch has made every effort to provide complete and accurate information in this manual, Monarch shall not be liable for any omissions or inaccuracies. Any update will be incorporated in a later edition of this manual.

WARNING

This equipment can interfere with radio communication if not installed and used in accordance with the instruction manual. It has been tested and found to comply with the limits for a Class A computing device pursuant to FCC Rules, Subpart B, Part 15, which provide reasonable protection against such interference when operated in a commercial environment. Operation in a residential area is likely to cause interference which the user must correct at their own expense.

CANADIAN D.O.C. WARNING

This digital apparatus does not exceed the Class A limits for radio noise emissions from digital apparatus set out in the Radio Interference Regulations of the Canadian Department of Communications.

Le présent appareil numérique n'émet pas de bruits radioélectriques dépassant les limites applicables aux appareils numériques de la classe A prescrites dans le Règlement sur le brouillage radioélectrique édicte par le ministère des Communications du Canada.

Preface

This manual contains information about the general setup and maintenance of the 9445™ printer. Some of the features in this manual may not be available on your printer.

Other 9445 manuals include:

<i>Operator's Handbook</i>	Explains how to enter data and print labels.
<i>User's Manual</i>	Explains how to create and enter formats. This manual also explains special setup functions for the printer.
<i>Programmer's Manual</i>	Explains communications and message structures for sending formats and batch data online.
<i>Messages Manual</i>	Lists error messages and operator responses.

Table of Contents

- 1. Installing the Printer** 1-1
- 2. Loading Supply** 2-1
 - Non-Peel Mode 2-1
 - Peel Mode 2-8
 - Loading Fan-Fold Supply 2-16
 - Adjusting the Supply Sensor 2-18
 - Adjusting the On Demand Sensor..... 2-20
- 3. Loading a Ribbon**..... 3-1
 - Loading a Ribbon Roll..... 3-2
 - Loading a Ribbon Cassette..... 3-6
- 4. Adjusting the Display** 4-1
- 5. Cleaning the Printhead and Platen Roller** 5-1
- Appendix A. Converting the Keyboard for Table Top Use** A-1
- Appendix B. Troubleshooting** B-1
 - "Head Test Failure" Message B-1
 - Start-Up and Printing B-2
 - Start-Up and Printing (continued) B-3
 - Cutting..... B-4

Table of Contents

Appendix C. Specifications C-1
 Printer C-1
 Supplies C-2

1. Installing the Printer

1. Place the printer on a level surface.
2. To install the keyboard on top of the printer:
 - a. Remove the cord from the base of the keyboard.
 - b. Plug the cord from the keyboard into the socket.
 - c. Insert all of the cord except a few coils back into the base. Secure the cord by sliding a coil into the slot in the base.
 - d. Place the keyboard in the recess on top of the printer as shown.

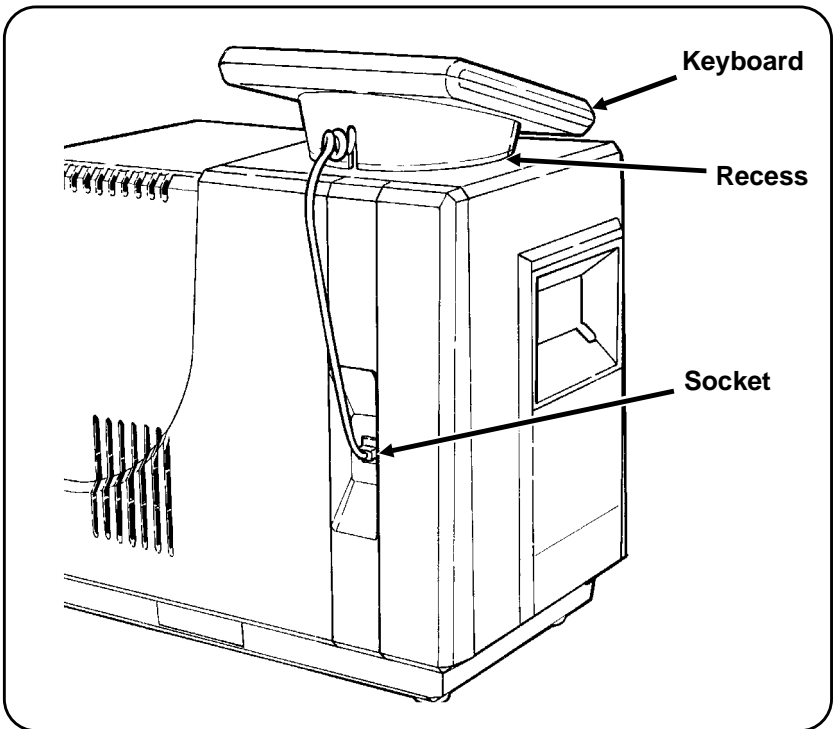

CAUTION

If your 9445 printer has been in storage below room temperature, allow 10-12 hours for the printer to adjust to room temperature **before** turning the power on. Failure to do this may damage the printer.

3. Turn the power switch off and insert the power cord into the socket. Plug the other end of the cord into a **grounded** 115 VAC electrical outlet.

NOTE: If you are going to use the printer online, also connect the RS-232 cable.

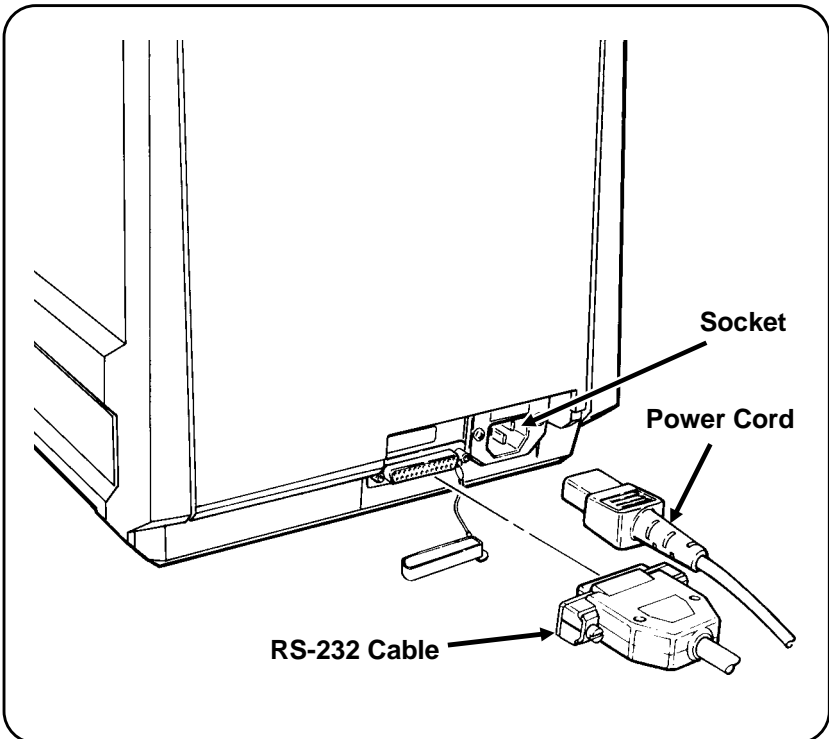

4. On the initial startup, leave the printer on for 24 hours to charge the new backup batteries.

2. Loading Supply

The printer prints both tags and labels. The supply may be wound with the printable side on either the inside or the outside.

This chapter explains how to load supply for

- Non-Peel Mode Printing (labels are printed in one strip. This can be used with Continuous Printing.)
- Peel Mode Printing (one label at a time while the backing paper rewinds inside the printer. This must be used with On Demand Printing.)
- Fan-Fold Mode Printing (fan-fold supply is printed in one strip). Call Service if you would like to use fan-fold supply.

NOTE: If your printer has a knife, follow the instructions under "Non-Peel Mode." You cannot use On Demand printing with a knife. Also, if your printer has a knife, it does not have the take-up spool shown in the instructions for loading supply.

If you are going to use thermal direct supply (no ribbon) and your printer is equipped with a ribbon roll adapter, turn the thermal supply indicator to the right. (See "Loading a Ribbon Roll" in Chapter 3.)

Non-Peel Mode

This mode is for both tags and labels. The printer dispenses the desired amount of supply without separating the backing paper from the label. This mode is usually used with continuous printing.

1. Open the front panel.

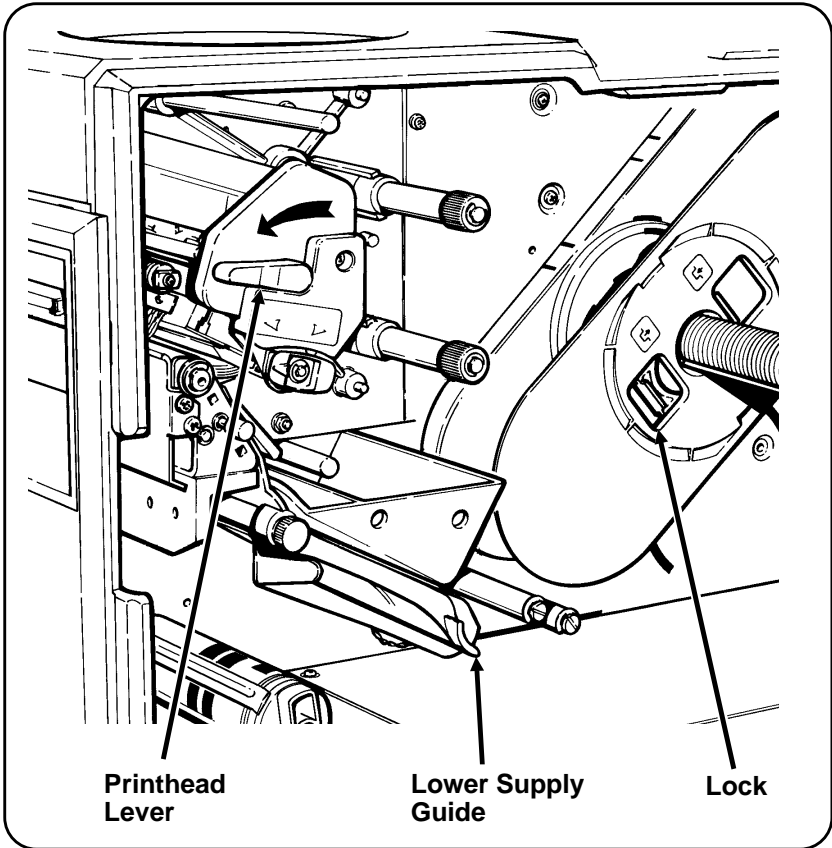

2. Turn the printhead lever to the left to release the printhead.
3. Hold down the lower supply guide and rewind the old supply roll, if there is one.
4. Release the lower supply guide.

CAUTION

If you run out of supply while printing, pull the supply strip back through the printer. **DO NOT** pull it forward through the printhead. Pulling it forward may cause jamming.

5. Push the lock to the right to unlock the outer supply holder and remove the outer supply holder from the supply shaft. Remove the old supply core, if there is one.

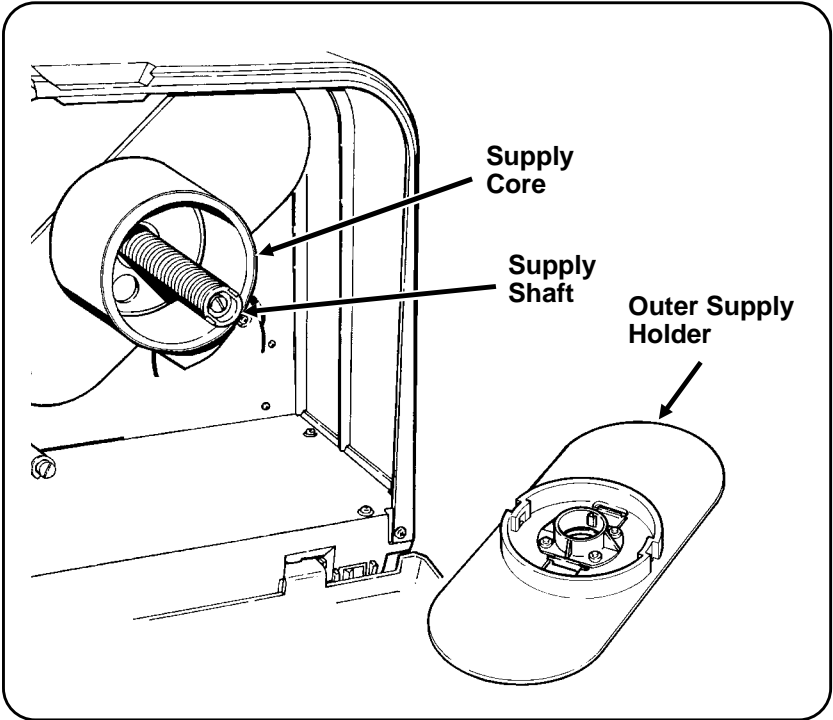

- Place the new supply roll on the supply shaft as shown.

NOTE: If your supply has a 3-inch (76.2 mm) core:

- Remove the hub from the inner supply holder.
- Reverse the outer supply holder (so the smooth side faces the supply).

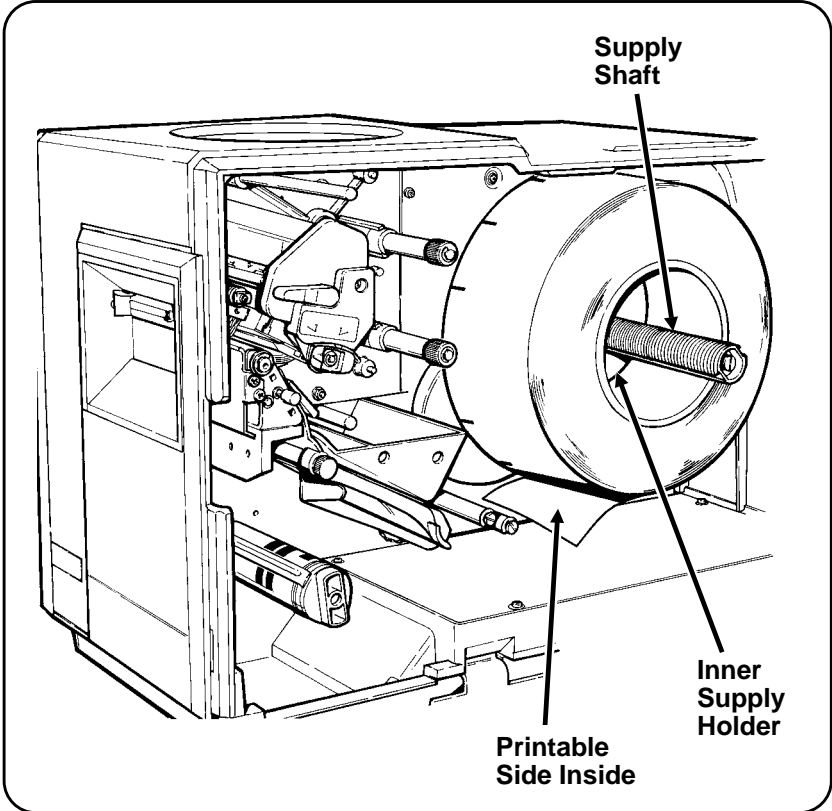

- Fit the supply core onto the inner supply holder and hold it in place.

8. Turn the outer supply holder so the lock faces out. Align the supply holder tabs with the tracks on the shaft.
9. Push the supply holder onto the supply shaft, against the supply. **Make sure the supply is free to unwind.**
10. Push the lock to the left to secure the outer supply holder.

NOTE: When the outer supply holder is reversed (for 3-inch core supply), push the lock to the right to secure the outer supply holder.

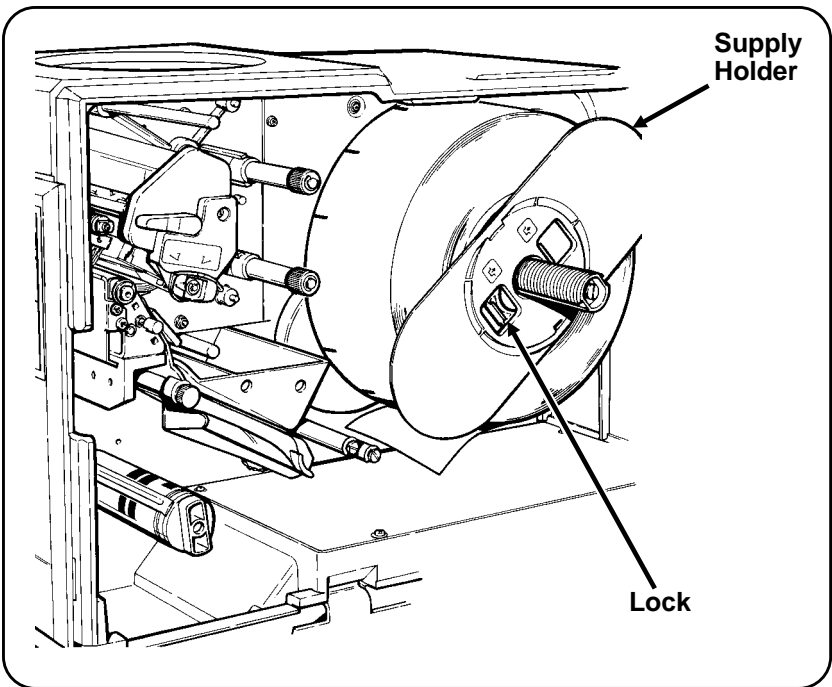

11. Pull enough supply from the roll to reach the printhead.
12. Hold down the lower supply guide.
13. Feed the supply past the out-of-stock switch, between the upper and lower supply guides, and up past the printhead.

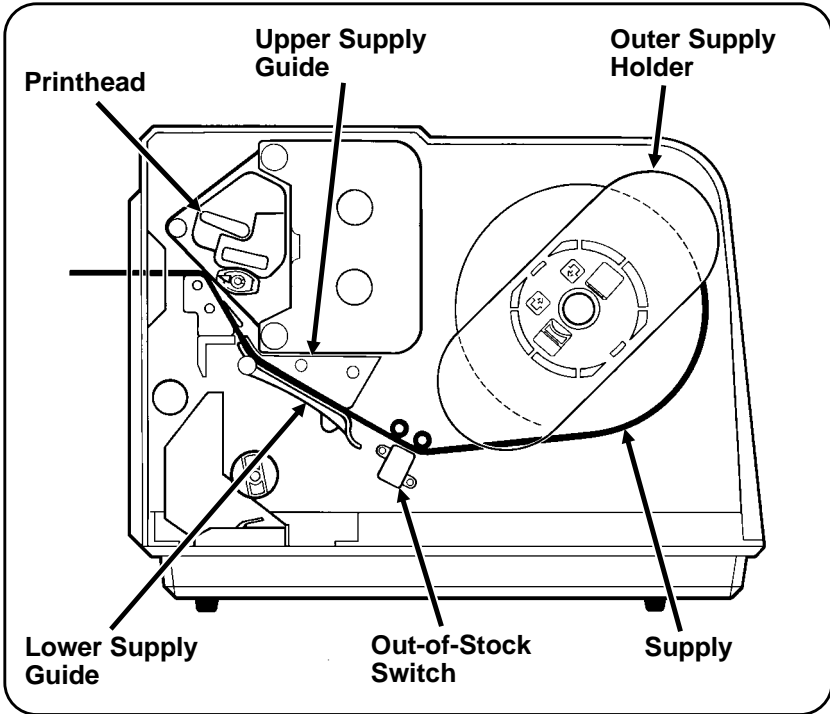

14. Align the supply with the top edge of the upper guide and slide it against the back wall (away from you). Continue threading the supply up to the printhead as shown. ***Make sure the ribbon does not snag or wrinkle.***

15. To adjust for wide or narrow supply, turn the supply width adjustment knob to:

- **NARROW** for supply **two inches in width or smaller**.
- **WIDE** for supply **greater than two inches in width**.

NOTE: Be sure the adjustment knob snaps back into place after you turn it.

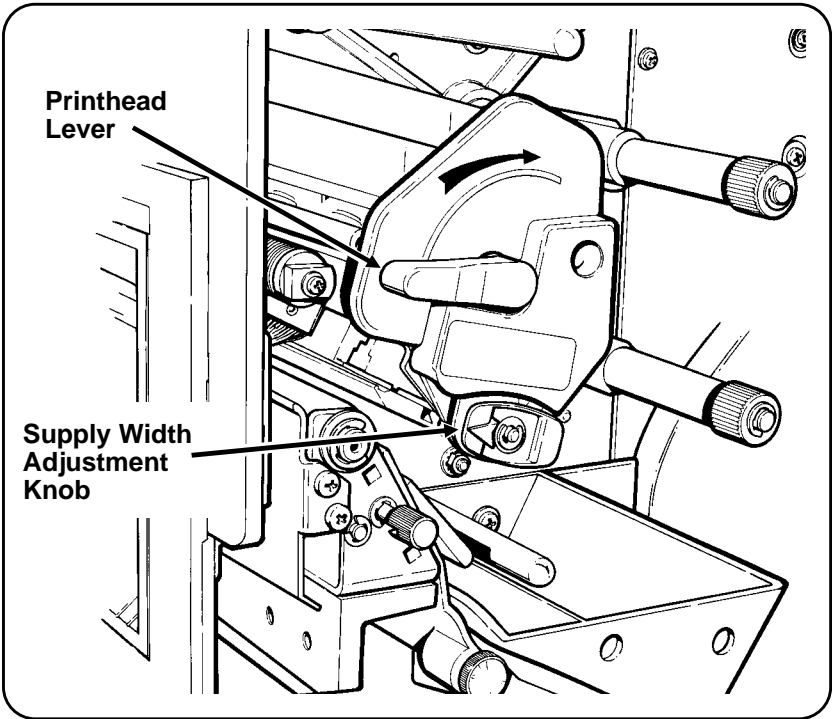

16. Turn the printhead lever to the right to lock the printhead.

17. Turn the printer on. If you are:

- replacing the supply with a new roll of the same size, press Ⓣ to align the printer.
- changing supply size, adjust the supply sensor. See "Adjusting the Supply Sensor" later in this chapter.

NOTE: Before you print, be sure the menu supply type setting matches your supply type (e.g. Black Mark/Die Cut). See your *Operator's Handbook* to set supply options.

Peel Mode

This mode is only used with labels. The printer separates the label from the backing paper. This mode must be used with On Demand printing.

1. Open the front panel.
2. Turn the printhead lever to the left to release the printhead.

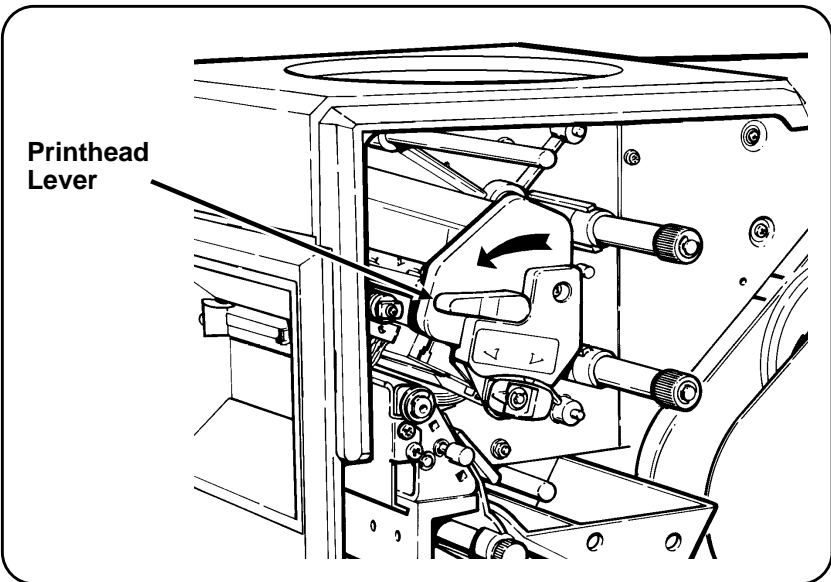

3. If you are reloading supply:
 - a. Cut the backing paper in front of the paper take-up spool, and then manually rewind the supply roll.
 - b. While holding the backing paper with one hand, turn the take-up spool knob counterclockwise about 1/4 turn with the other hand.
 - c. Slide the backing paper off the take-up spool.

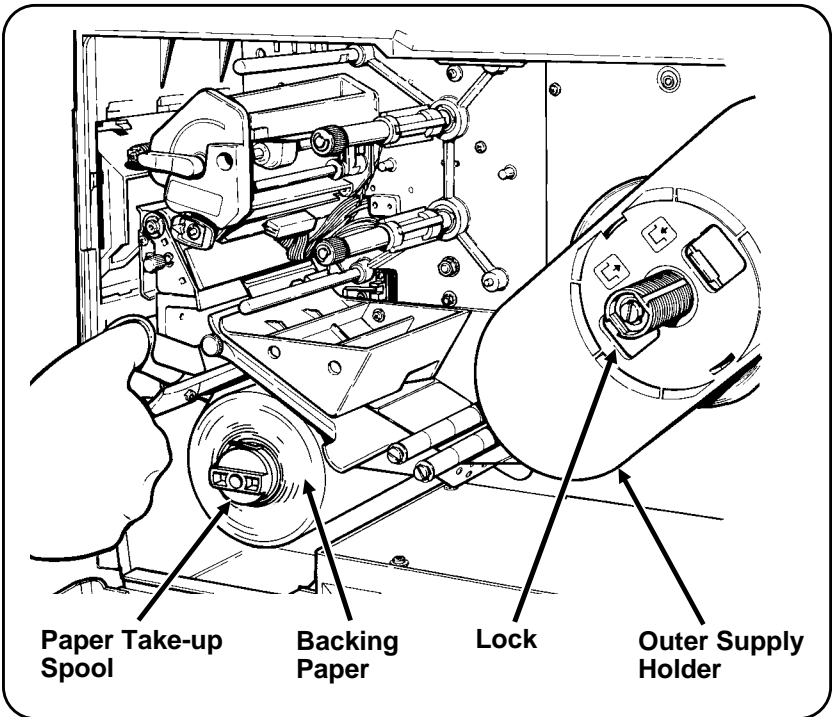

4. Push the lock to the right to unlock the outer supply holder and remove the outer supply holder from the supply shaft. Remove the old supply core, if there is one.
5. Remove labels from the first 16 inches of backing paper (on the new supply roll).

- Place the new supply roll on the supply shaft as shown.

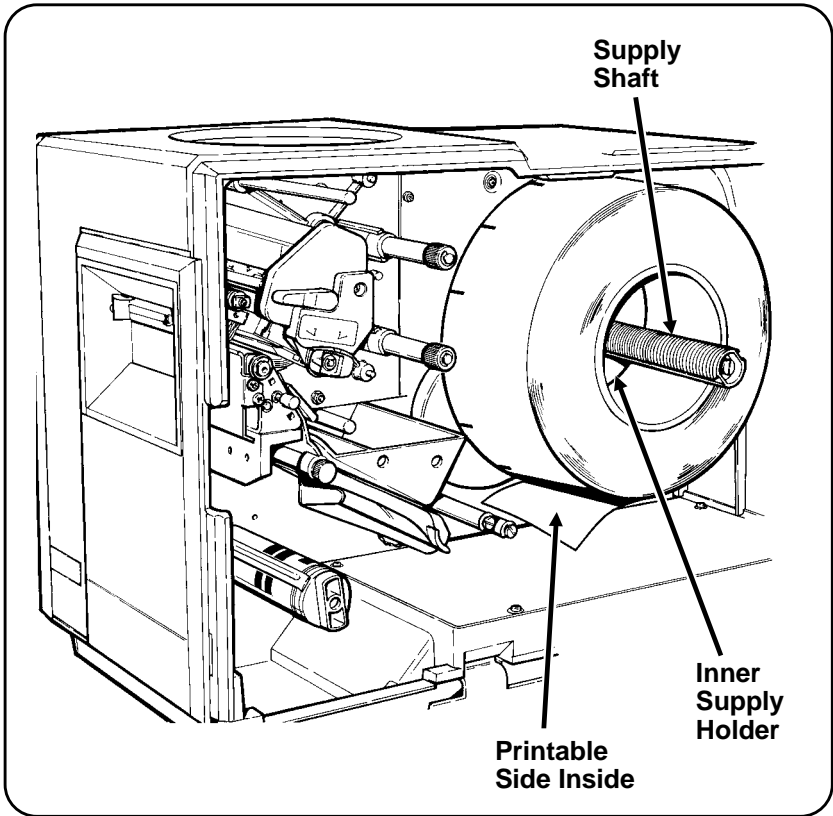

NOTE: For 3-inch (76.2 mm) cores:

- Remove the hub from the inner supply holder.
 - Reverse the outer supply holder (so the smooth side faces the supply).
- Fit the supply core on the inner supply holder and hold it in place.

8. Turn the outer supply holder so the lock faces out. Align the supply holder tabs with the tracks on the supply shaft.
9. Push the supply holder onto the supply shaft, against the supply. **Make sure the supply is free to unwind.**
10. Push the lock to the left to secure the outer supply holder.

NOTE: When the outer supply holder is reversed (for 3-inch core supply), push the lock to the right to secure the outer supply holder.

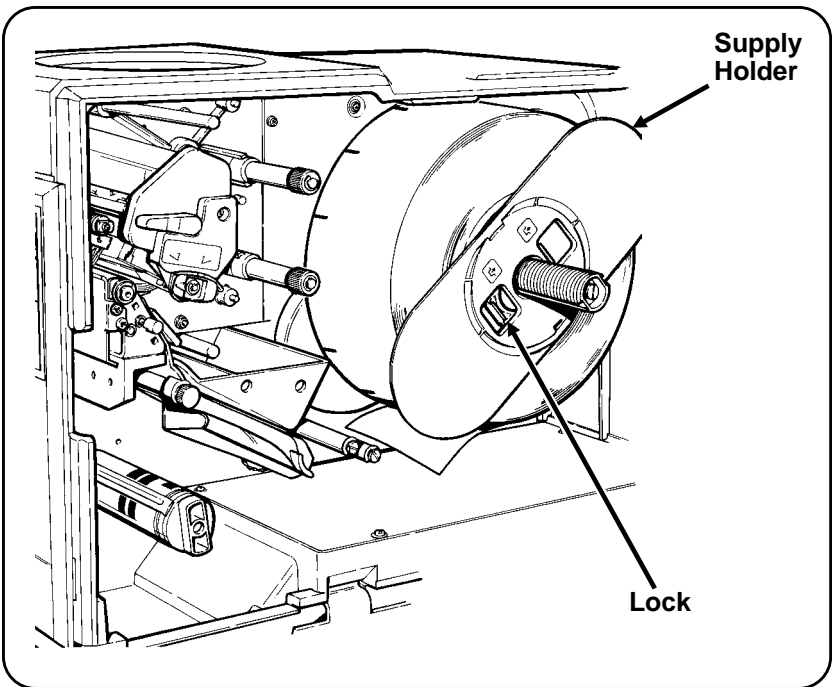

11. With one hand, hold down the lower supply guide. With the other hand, feed the backing paper between the lower and upper supply guides, past the printhead and down to the paper take-up spool. Then release the lower supply guide.
12. While holding the paper take-up spool with one hand, turn the knob **counterclockwise** (1/4 turn) with the other hand. This opens the clamp on the paper take-up spool.

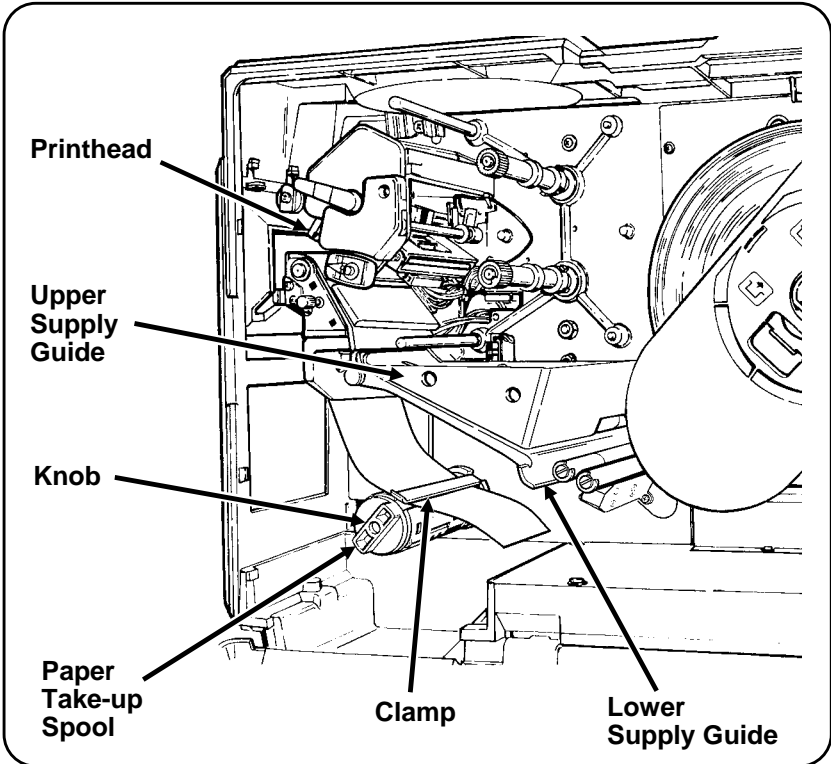

13. Insert the backing paper under the clamp.

14. Turn the supply roll **counterclockwise** to remove any slack in the backing paper. Your supply and backing paper should be fed as shown.

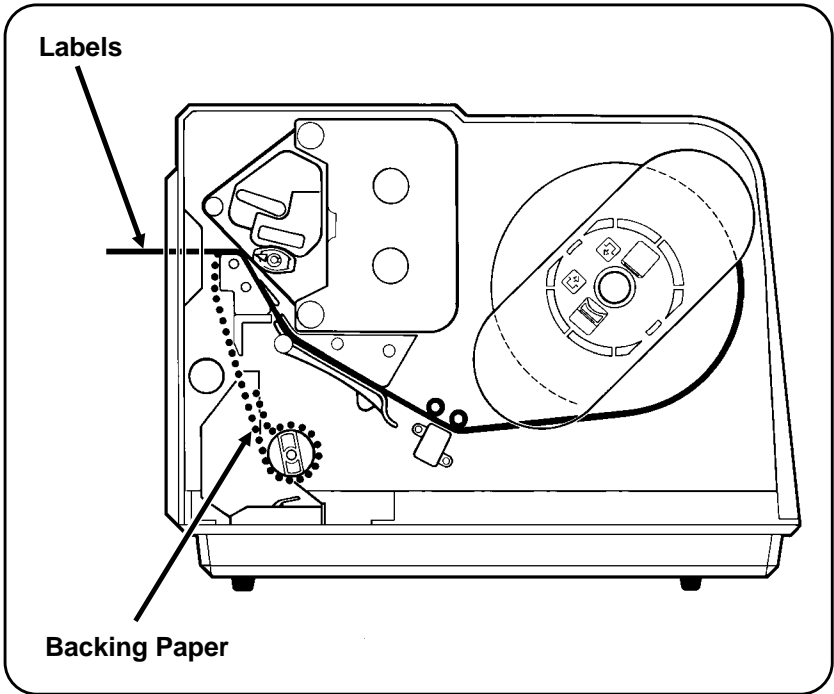

15. To adjust for wide or narrow supply, turn the supply width Adjustment Knob to:

- **NARROW** for supply **two inches in width or smaller**
- **WIDE** for supply **greater than two inches in width.**

NOTE: Be sure the adjustment knob snaps back into place after you turn it.

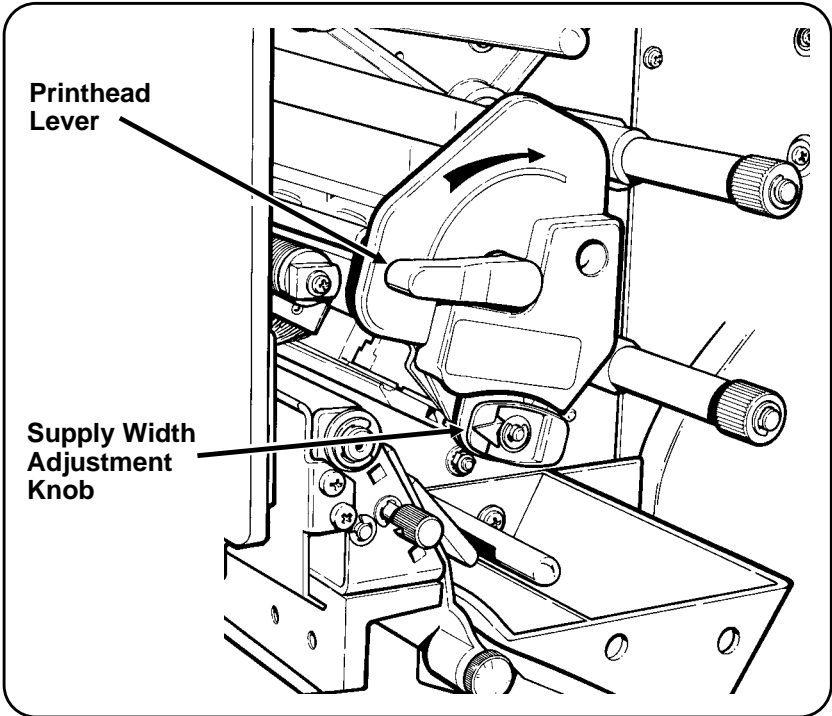

16. Turn the printhead lever to the right to lock the printhead.

17. Turn the printer on. If you are:

- replacing the supply with a new roll of the same size, press Ⓣ to align the printer.
- changing supply size, adjust the supply sensor. See "Adjusting the Supply Sensor" later in this section.

NOTE: Before you print, be sure the menu supply type setting matches your supply type (e.g. Black Mark/Die Cut). See your *Operator's Handbook* to set supply options.

CAUTION

Turning the printer on and off rapidly can cause it to malfunction. If you have turned the printer on (or off), wait ten seconds before turning it back off (or on).

Loading Fan-Fold Supply

The 9445 has the ability to print fan-fold supply with the optional fan-fold printer cover. If your printer does not have a fan-fold slot, contact Monarch Service to order a fan-fold printer cover.

To load fan-fold supply:

1. Open the front panel.
2. Open the printhead by turning the printhead lever to the left.
3. Fan all four sides of the supply stack and straighten any curved or bent corners. This will prevent supply from sticking together and causing feed jams.
4. Place the supply approximately one fan-fold length behind the printer, label side up.

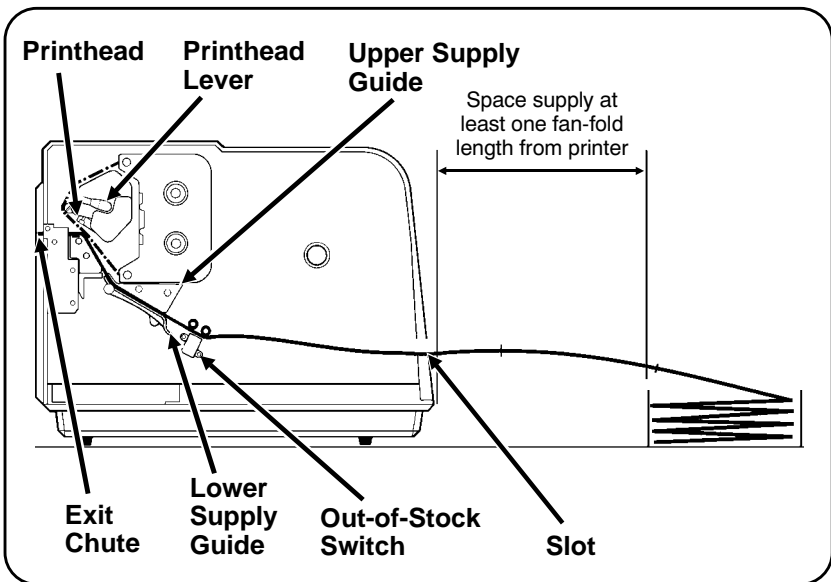

5. Feed the supply through the slot in the back of the printer and past the out-of-stock switch.

6. With one hand, hold down the lower supply guide. With the other hand, feed the backing paper between the upper and lower guides, past the printhead, and then out through the exit chute.

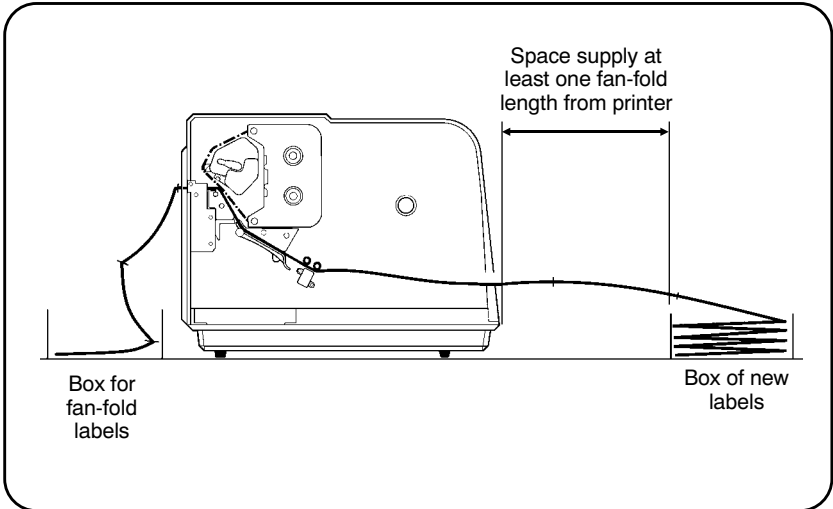

7. Close the printhead by turning the printhead lever to the right.
8. Place an empty box below the printer's exit chute to catch the labels as they are printed.

NOTE: Check the stack of printed labels a few times during the print job to make sure the labels fold at the same points at which they were folded before printing. If you remove some or all of the printed labels, check that the order of the folds is correct before you resume printing.

Adjusting the Supply Sensor

The supply sensor controls how much supply feeds between tags or labels. The sensor reads black marks or feed apertures.

To read black marks or apertures, the sensor must be aligned with the black mark or aperture on the tag. Otherwise, you'll see an error message when you try to print a batch.

When moving the sensor, turn the sensor adjustment knob:

- **CLOCKWISE** to move the sensor away from the inside edge of the supply.
- **COUNTERCLOCKWISE** to move the sensor toward the inside edge of the supply.

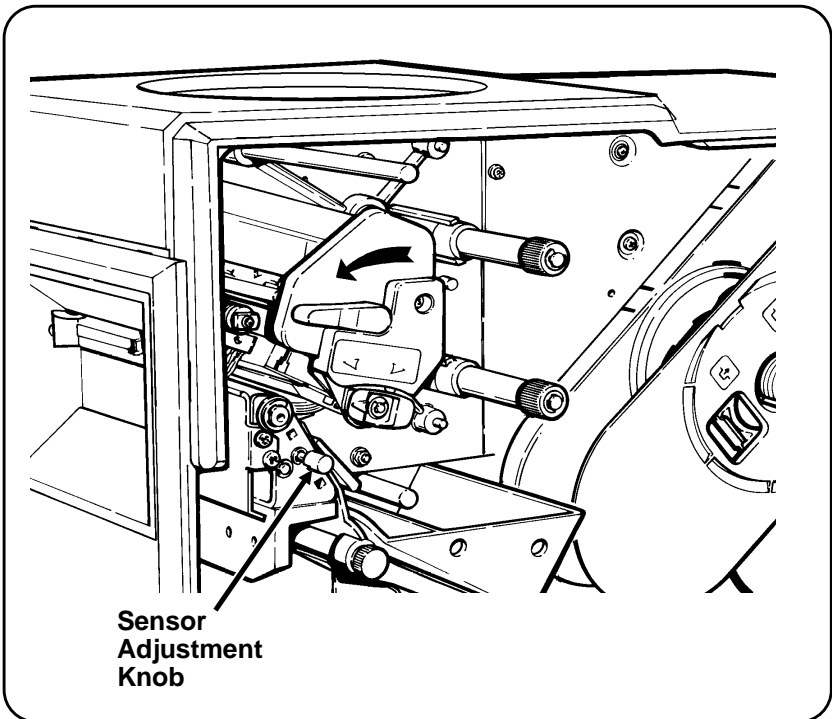

Die cut supply requires no sensor adjustment.

1. Do one of the following:

For black mark supply, turn the sensor adjustment knob **counterclockwise** until it stops. Do not force the knob.

For feed apertures, turn the sensor adjustment knob **counterclockwise** until it stops. Then turn the knob **clockwise** as determined below.

- Measure from the edge of the supply to the center of the aperture.
- Subtract 1/8 inch (3.1 mm) from the measurement.
- Multiply the result by 36 (if you are measuring in millimeters, multiply by 1.41).

For example, if the measurement to the aperture center is 3/8 inch (9.5 mm), turn the knob 9 turns to center the sensor.

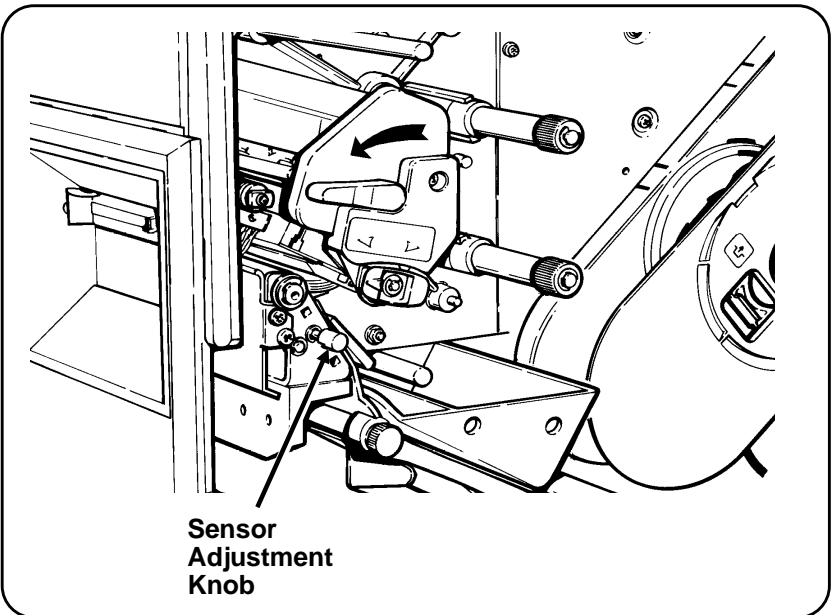

2. Close the front panel.

Adjusting the On Demand Sensor

The On Demand sensor stops the printer between tags or labels when you print in the On Demand mode. The sensor detects the presence of supply in the exit chute of the printer. When you remove the tag or label, another tag or label prints.

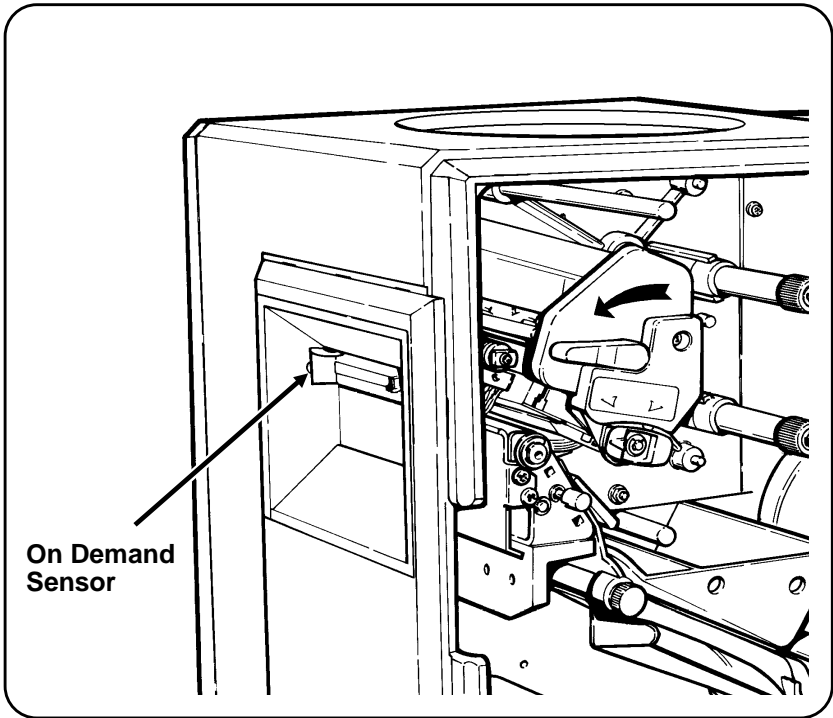

NOTE: The On Demand sensor must be positioned over a white or light area on the supply. If it is positioned over a dark area, the entire batch may print before the printer stops.

You can adjust the On Demand sensor either right or left by pushing it with your finger.

3. Loading a Ribbon

There are two types of supplies:

Thermal Direct specially treated thermal supplies that don't use a ribbon for printing.

Thermal Transfer standard supplies that require a ribbon for printing.

NOTE: DO NOT load a ribbon when printing on thermal direct supplies.

When installing a ribbon, remember

- Ribbons may catch on supplies left in place.
- Supplies can misalign the ribbon as you move the supply up to the feed mark.
- The width of your ribbon must closely match the width of your supply.

To install a ribbon roll, refer to "Loading a Ribbon Roll," later in this chapter. To install a ribbon cassette, refer to "Loading a Ribbon Cassette," later in this chapter.

Loading a Ribbon Roll

To load a ribbon roll:

1. Open the front panel.
2. Turn the printhead lever to the left to release the printhead.
(Also see the supply loading figure inside the front panel.)

NOTE: If the printer has supplies loaded for continuous printing, pull the leading edge back to the upper supply guide before loading the ribbon.

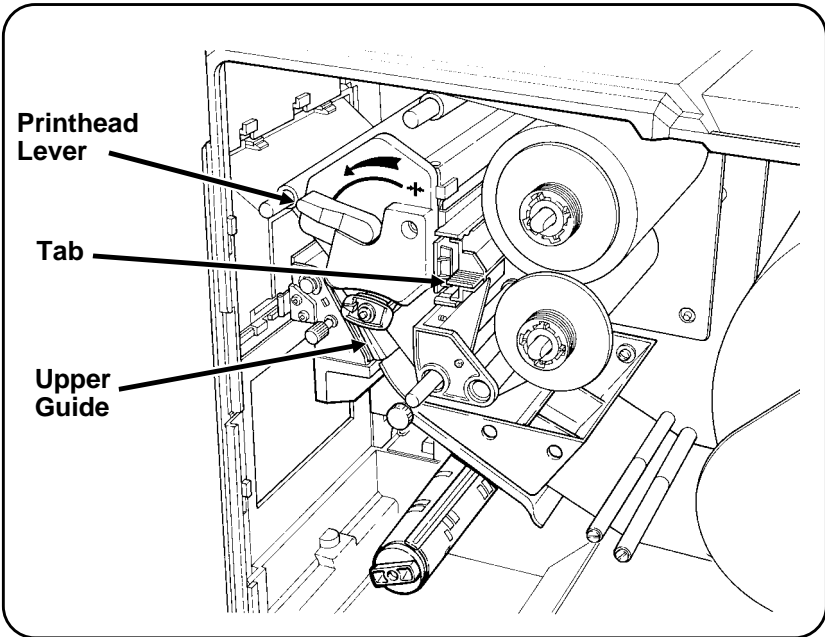

3. Grasp the tab on the ribbon roll adapter and pull it out until the adapter locks into the extended position.

4. Pull the ribbon spool holders off. Remove the old ribbon (if there is one).
5. Be sure the thermal supply indicator is pointing upward.

NOTE: Turn the thermal supply indicator to the right only if you are going to use thermal direct supplies (no ribbon).

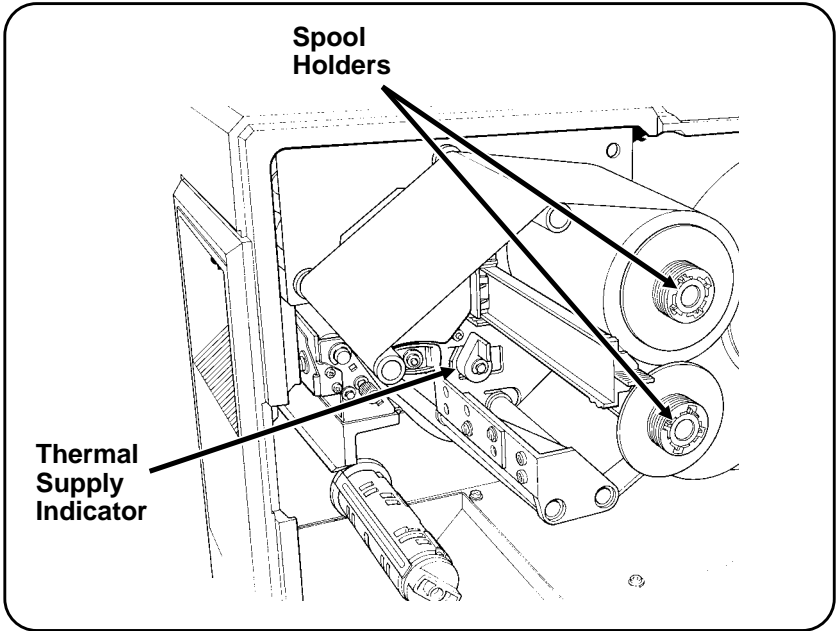

6. Load a new ribbon onto the lower spool shaft so the ribbon unwinds **clockwise**.

7. Guide the new ribbon around the rollers on the ribbon roll adapter. Slide the upper spool onto the upper spool shaft.

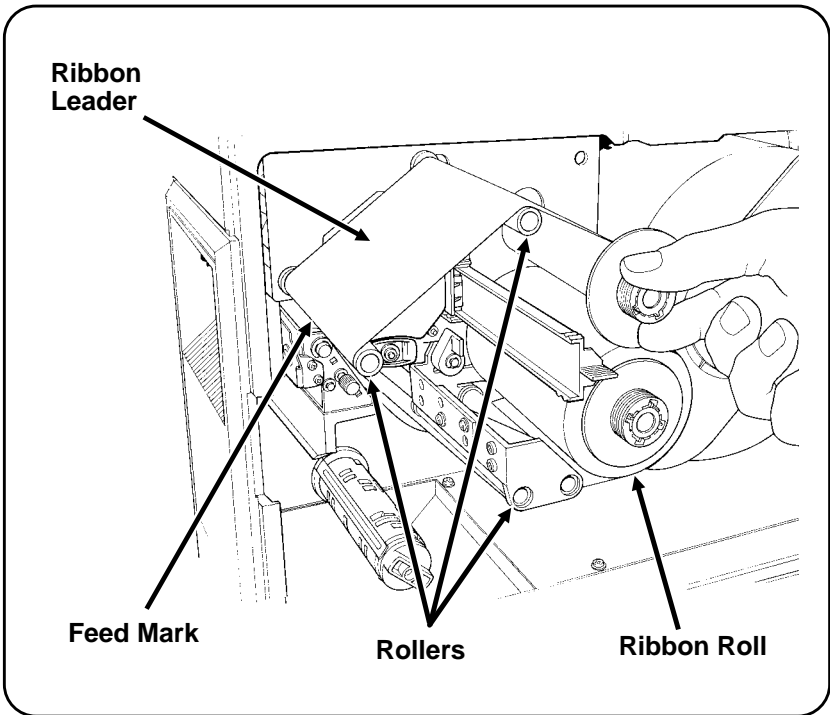

8. Slide the ribbon spool holders against the spools.
9. Turn the upper ribbon spool **clockwise** to add slight tension to the ribbon. ***Make sure the ribbon is tight but not wrinkled or bunched.***
10. Slide the ribbon roll adapter in against the back wall of the printer

NOTE: To help slide the ribbon roll adapter in or out, it may be necessary to increase or relax tension on the ribbon by turning the spools.

11. Turn the upper ribbon spool **clockwise** until the black part of the ribbon is past the feed mark.
12. If the printer has supplies loaded for continuous printing, slide the supply up to the feed mark. ***Make sure the ribbon is correctly positioned.***
13. Turn the printhead lever to the right to move the printhead against the ribbon and the supply.
14. Close the front panel.

Loading a Ribbon Cassette

To load a ribbon cassette:

1. Open the front panel.
2. Turn the printhead lever to the left to open the printhead. (Also see the supply loading figure inside the front panel.)

NOTE: If the printer has supplies loaded for continuous printing, pull the leading edge back to the upper guide before loading the ribbon cassette.

3. Remove the old ribbon cassette if necessary.

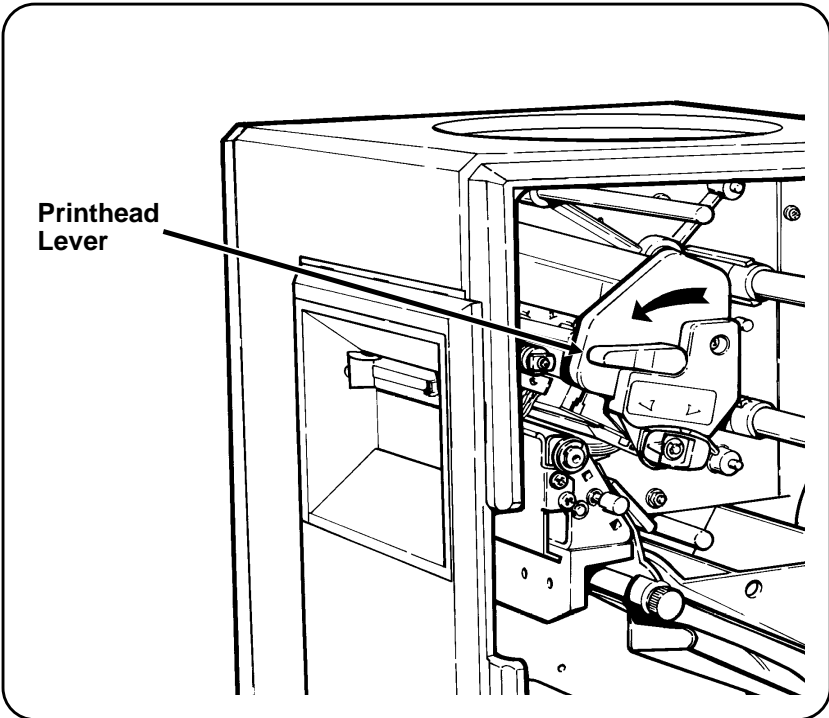

4. Remove the new ribbon cassette from the package. Then loosen ribbon from cassette as shown below.

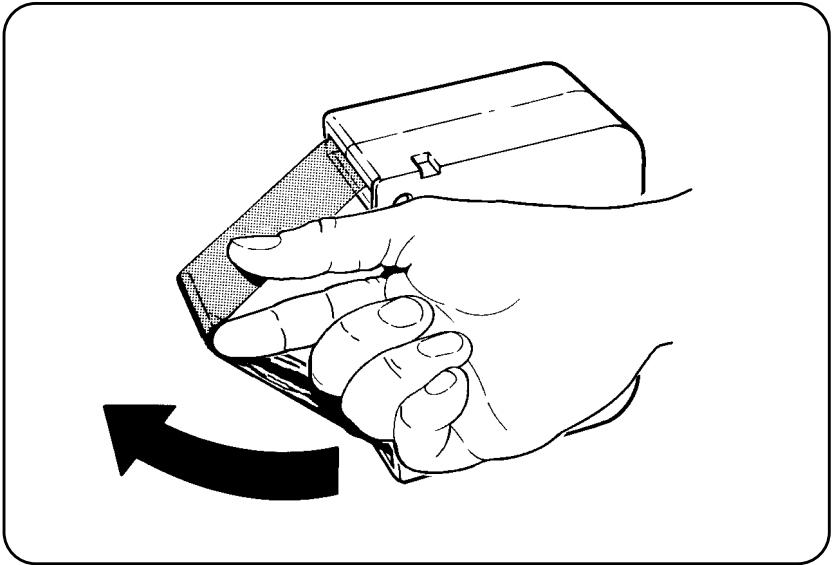

5. Guide the edge of the ribbon around the ribbon guide post.
6. Place the cassette on the ribbon spools and push it against the back wall. The spool lock will drop out.

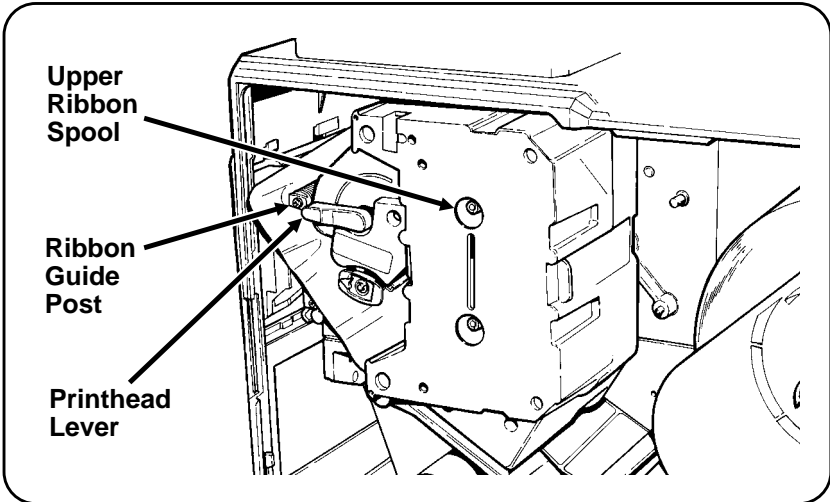

7. Turn the upper ribbon spool **clockwise** until the ribbon is tight. ***Make sure the ribbon is not wrinkled or bunched.***
8. Slide the supply up to the feed mark. ***Make sure the ribbon is correctly positioned.***
9. While holding the cassette in place, turn the printhead lever to the right to lock the printhead in place. Do not force the lever.
10. Close the front panel.

4. Adjusting the Display

The intensity adjustment wheel is on the right side of the keyboard. Rotate the wheel to lighten or darken the display.

NOTE: See your *Operator's Handbook* for a description of the keyboard keys.

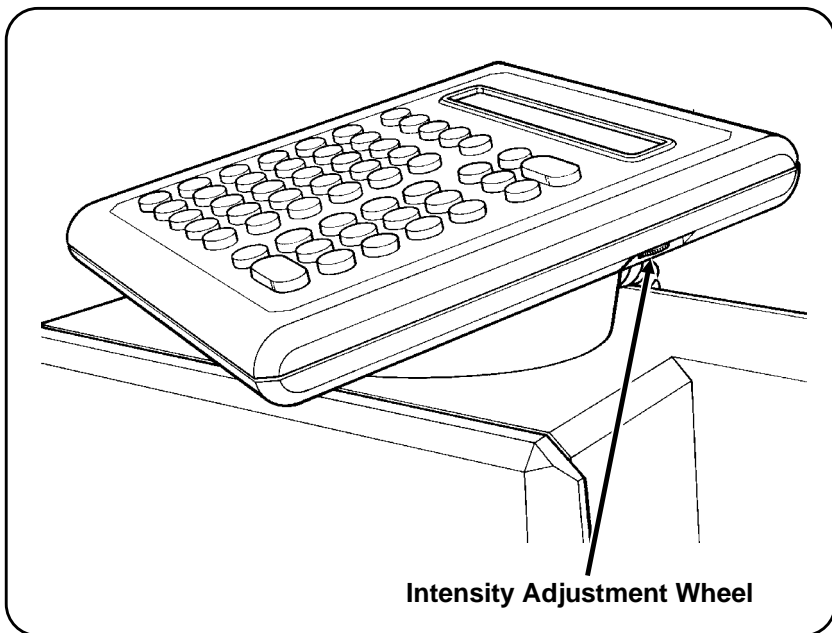

5. Cleaning the Printhead and Platen Roller

WARNING

Turn the power off and unplug the power cord before cleaning.

1. Open the front panel.
2. Turn the printhead lever to the left to open the printhead.
3. Wind the supplies back onto the supply roll.
4. Remove the ribbon cassette if one is loaded.

CAUTION

DO NOT use sharp or abrasive materials to clean the printhead. This can damage the printhead and void your warranty.

5. Lightly moisten a cotton swab with alcohol and rub it back and forth across the printhead. Clean the platen roller the same way.

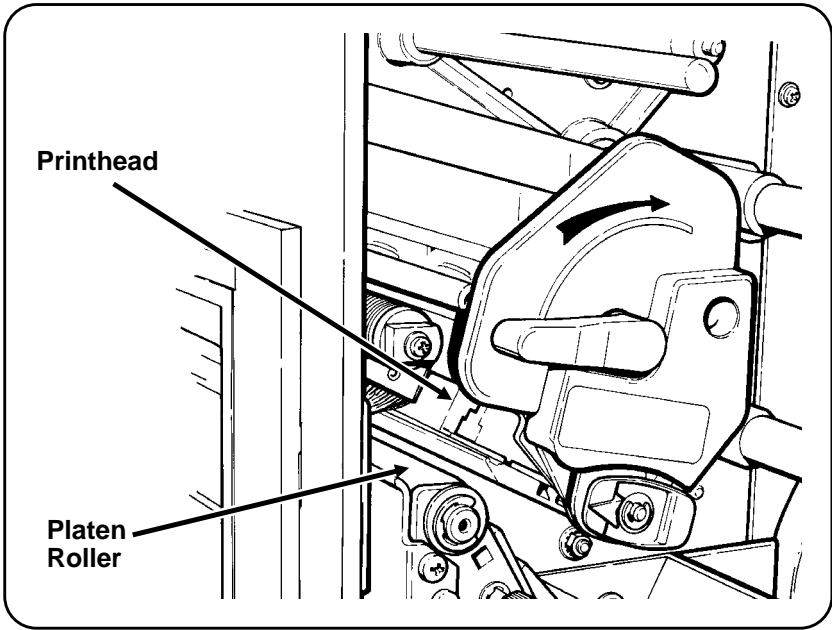

6. Reload the supply and ribbon cassette, if necessary, and close the printhead.
7. Turn the power on.
8. Press \downarrow twice to realign the supply.
9. If printing is not improved, call Monarch Service.

Appendix A. Converting the Keyboard for Table Top Use

1. Lift the keyboard from the printer and place it on the table.

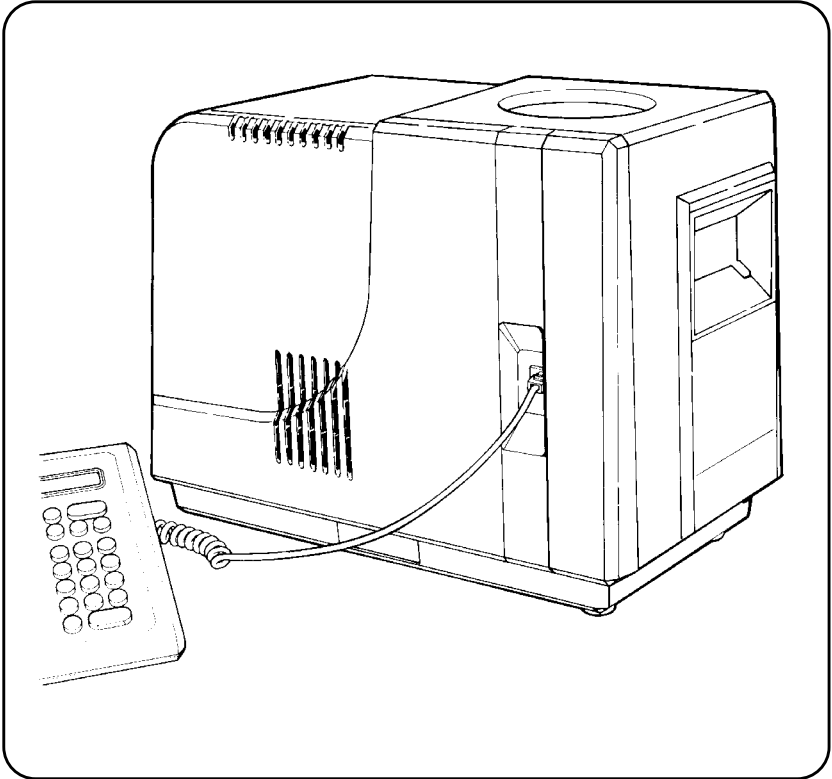

2. Turn the keyboard over and remove the length of cord you need.
3. Slide a coil of the cord into the slot to hold it in place.

Appendix B. Troubleshooting

If you cannot fix a problem, call Monarch service.

"Head Test Failure" Message

The 9445 performs a printhead test when you turn on the printer. If the printhead test fails for any reason (bad connection, bad dot), the printer displays "Head test failure."

If you receive this error:

1. Press  to clear the message.
2. Print a test label (or one of the actual labels you plan to print).
3. Check for any visible print problems and do one of the following:
 - If there are no visible print problems, continue printing.
 - If there is a visible print problem in a bar code, call Monarch Service. You can check the quality of your bar code if you have a bar code verifier.
 - If there is a visible print problem that is not in a bar code, but is acceptable to you, continue printing.
 - If there is a visible print problem that is not in a bar code and is not acceptable to you, call Monarch Service.









Start-Up and Printing

Problem	Action
Error message appears during start-up.	Turn power off, then on and try again. If an error message appears again, call Monarch Service.
"Check ribbon" message appears.	Load a new ribbon roll or cassette.
	Reload ribbon cassette.
Heavy printing.	Adjust print contrast.
	Clean the printhead.
	Change supply.
	Reload ribbon cassette.
Light printing.	Adjust print contrast.
	Change supply.
	Reload ribbon cassette.
No print.	Change supply.
	Correct the format in Format Entry mode, or send a corrected format online.
	Change ribbon cassette.
Partially printed data.	Change ribbon cassette.
	Correct the format in Format Entry mode or send a corrected format online.

Start-Up and Printing (continued)

Problem	Action
Printed data becomes misaligned.	Recalibrate the printer. Select Printer Options from the main menu, then select Define Supply Type. Select A)align to recalibrate the printer.
Printed data wraps around.	Change supply.
	Correct the format in Format Entry mode or send a corrected format online.
Printing shadows or smears.	Clean the printhead.
	Change supply.
	Reload ribbon cassette.
Voids in printing.	Clean the printhead.
	Change supply.
	Reload ribbon cassette.

Cutting

Problem	Explanation
Cut length is more than 0.03 inches from tag length.	Call Monarch Service.
"Knife jam" message appears.	Paper is jammed in knife. Clear paper and clean away any gum residue.
	Knife out of position. Press  , then press  twice to adjust the knife. Then press  twice to clear the message.
	Blades are worn. Call Monarch Service.
No cut action (or sound) when  key is pressed.	Knife is out of position. Press  , then press  twice to adjust the knife. Then press  twice to clear the message.
	Knife is locked. Unlock knife.
	Your printer is not equipped with a knife.
No cut action when  key is pressed, but there is a slight hum.	Call Monarch Service.

Appendix C. Specifications

Printer

Height:	14.5 inches (368.30 mm) without keyboard; 17.7 inches (449.58 mm) with keyboard.
Weight:	35 lbs. (15.88 kg) packaged.
Power:	115 volts, 60 Hz. (standard) 220 volts, 50-60 Hz. (optional).
Fuse:	3 amps.
Operating and Storage limits:	40°F to 104°F (4°C to 40°C).
Relative Humidity:	5% to 90% (no condensation).
Display:	Liquid crystal display with 2 lines 32 characters per line (alphanumeric).
Printhead:	Thermal at 4.15 inches (105.41 mm) wide 192 dots per inch (7.6 dots per mm) 0.06 inch (1.5 mm) reserve non-print area.
Printing Method:	Thermal transfer (ribbon) or thermal direct.
Ribbon Type:	One-time carbon; black.
Ribbon Storage:	41°F to 95°F (5°C to 35°C). DO NOT leave ribbons in direct sunlight, high temperatures, or high humidity.

Print Speed

With ribbon:

- Bar code toward top/bottom of tag
3.6 IPS
- Bar code toward left/right side of tag
2.5 IPS

Print Speed

Without ribbon:

- Bar code toward top/bottom of tag
3.6 IPS
- Bar code toward left/right side of tag
2.5 IPS

*IPS = Inches per second

Supplies

Supply Types:

Thermal transfer stock or thermal direct stock.

Width

(without knife)

Minimum: 1.0 inch (25.4 mm)
Maximum: 4.5 inches (114.3 mm).

Width

(with knife)

Minimum: 1.0 inch (25.4 mm)
Maximum: 4.0 inches (101.6 mm).

Length

Minimum: 0.75 inch (19.05 mm)
Maximum: 8.0 inches (203.2 mm).

Supply Thickness:

Tags or Labels: 0.006 to 0.010 inch
(0.152 to 0.355 mm).

Roll Diameter:

Maximum 9.0 inches (228.6 mm)

For supplies, service, or assistance call:

TOLL FREE:

1-800-543-6650 (In U.S.A.)

1-800-263-4650 (In Canada)